



GAI-TRONICS® CORPORATION  
A HUBBELL COMPANY

# Model 227-003, 257-003, and 277-003 Auto-dial S.M.A.R.T. Phones

## TABLE OF CONTENTS

<b><i>Getting Started</i></b> .....	<b>1</b>
<b>Product Overview</b> .....	<b>1</b>
<b>Standard Operation</b> .....	<b>2</b>
Volume Control Button.....	2
To Receive a Call.....	2
To Place a Call.....	2
<b><i>Installation</i></b> .....	<b>3</b>
<b>Safety Guidelines</b> .....	<b>3</b>
<b>General Installation Guidelines</b> .....	<b>3</b>
Tamper-Resistant Hardware .....	3
Conduit Installation Details .....	3
<b>Model 227-003</b> .....	<b>5</b>
<b>Model 257-003</b> .....	<b>7</b>
<b>Model 277-003</b> .....	<b>9</b>
Stanchion or Flush-mount Applications .....	9
Surface Mount Applications.....	10
<b>External Power</b> .....	<b>11</b>
<b><i>Setup</i></b> .....	<b>11</b>
<b>Hardware Configuration</b> .....	<b>11</b>
Auto-answer Configuration .....	11
Polarity Configuration.....	11
<b>Auxiliary Output</b> .....	<b>12</b>
<b>Programming</b> .....	<b>13</b>
Enter the Programming Mode.....	13
Basic Programming Commands.....	14
<b><i>Maintenance</i></b> .....	<b>16</b>
<b>Service</b> .....	<b>16</b>
<b>Preventive Maintenance for Model 277-003</b> .....	<b>16</b>
Cleaning .....	16
Prevention.....	16
<b><i>Specifications</i></b> .....	<b>17</b>
<b><i>Confidentiality Notice</i></b> .....	<b>20</b>



**GAI-TRONICS® CORPORATION**  
A HUBBELL COMPANY

# Model 227-003, 257-003, and 277-003 Auto-dial S.M.A.R.T. Phones

---

## Getting Started

### Product Overview

Thank you for your purchase of a GAI-Tronics S.M.A.R.T. telephone. In addition to providing standard emergency telephone operation, GAI-Tronics Self-Monitoring and Reporting Telephones (S.M.A.R.T.) incorporate leading-edge technology to provide optimum performance and flexibility. For example, when used with the GAI-Tronics Telephone Management Application (TMA) the health of each telephone is monitored and reported. For complete details, please refer to the on-line help included with TMA.

This manual applies to the following GAI-Tronics Auto-dial S.M.A.R.T. phones that include noise-canceling handsets:

Model	Description
<b>227-003</b>	<b>Tough Auto-dial S.M.A.R.T. Phone</b> – This weather-resistant, vandal-resistant, sand-cast aluminum unit is provided with a spring-loaded door and a handset with a 15-inch lanyard embedded armored cord. It is designed for use in remote areas under extreme conditions.
<b>257-003</b>	<b>Rugged Weatherproof Auto-dial S.M.A.R.T. Phone</b> – The enclosure for this phone is made of weatherproof, high impact glass-reinforced polyester, and can be equipped with a spring-loaded door.
<b>277-003</b>	<b>Flush-panel Auto-dial S.M.A.R.T. Phone</b> – This is a flush-mount phone with a heavy-gauge brushed stainless steel front panel that is designed to be wall-mounted indoors. It includes a 29-inch lanyard embedded armored cord.

The GAI-Tronics S.M.A.R.T. Phone product line provides the flexibility to address a diverse range of applications. A wide variety of functions can be achieved by altering the configuration data stored in the phone's non-volatile memory. These configuration options include:

- Call progress detection, control, and call logging
- Auto-calling, auto-answering, and auto-dialing facilities
- Function inhibiting (e.g. tone pad and manual keypad dialing)
- Maximum call duration

These functions are initially programmed during manufacturing and testing. After installation, they can be programmed remotely via DTMF data call.

All S.M.A.R.T. telephones are line-powered and can be connected to any of the following:

- Central Office (CO) line to the Public Switched Telephone Network (PSTN)
- 24 V dc or 48 V dc analog station port of Private Branch Exchange (PBX), Private Automatic Branch Exchange (PABX) or KSU.

Connection may not be made to pay phone extensions or shared service (party) lines.

TMA users can schedule auto-dial maintenance calls to alert maintenance personnel of any unusual sensor or fault conditions that exist. S.M.A.R.T. Phones can also be programmed to generate an auto-dial maintenance call when certain sensor events are discovered. Access to the S.M.A.R.T. Phone's maintenance mode is restricted through the use of the maintenance access PIN. The maintenance access PIN should be distributed only to trained maintenance personnel.

## Standard Operation

### Volume Control Button

The volume control button on the front of each phone is used to control the handset volume. Each press of the button increases the volume in four steps and then returns it to the original setting in a circular fashion.

### To Receive a Call

When the telephone rings:

1. Lift the handset.
2. Converse with the caller.
3. When finished, hang up the handset.

### To Place a Call

To place a call using manual dialing:

1. Lift the handset. (The telephone automatically dials the pre-programmed number).
2. Converse with the person answering the call.
3. When finished, hang up the handset.

# Installation



## ATTENTION

Installation should be performed by qualified personnel and only in accordance with the National Electrical Code or applicable local codes.

## Safety Guidelines

When installing any GAI-Tronics telephone equipment, please adhere to the following guidelines to ensure the safety of all personnel:

- Do not install telephone wiring during a lightning storm.
- **Electrostatic Discharge (ESD) Protection:** Your telephone may have an earth ground terminal provision. If so, ensure that it is connected to ground in accordance with all local safety regulations and the National Electrical Code (NEC). Grounding has to be ensured for safe and stable communications. Do not use long and coiled ground wires. Trim ground wires to the required length. Use a star configuration whenever possible. Please note proper grounding does not eliminate the need for lightning protection for the telephone or the telephone system.
- **Install a UL Listed lightning arrester** on any phone installed where the phone or phone cable is at risk of being exposed to lightning strikes. The lightning arrester must be installed as close as possible to maximize the protection. It must not be installed within the enclosure supplied with the phone. Please consult our Service Center at 800-492-1212 for further information.
- Do not install telephone jacks in wet locations unless the jack is specifically designed for wet locations.
- Do not touch uninsulated telephone wires or terminals unless the telephone line has been disconnected at the network interface.

## General Installation Guidelines

GAI-Tronics S.M.A.R.T. phones are designed to operate on telephone lines as detailed in the Product Overview section of this manual. The telephones are designed to operate with one telephone per line. If telephones are operated in parallel or “party line configuration” you may experience sporadic phone operation, difficulties with programming, or premature disconnection of calls. Additionally, if special features, e.g. voice mail, call waiting, etc. are not disabled, the phone may not function.

### Tamper-Resistant Hardware

Models 227-003 and 277-003 are vandal resistant, with the front panel for each telephone attached to its enclosure with tamper-resistant screws. A GAI-Tronics Model 233-001 Tamper-Resistant Screwdriver (sold separately) is recommended for installing the tamper-resistant screws. The Model 257-003 Telephone's front panel is attached with standard Phillips head screws.

### Conduit Installation Details

GAI-Tronics recommends installing telephone lines in conduit to protect against accidental damage and vandalism. To prevent moisture from entering the enclosure, we strongly recommend the following:

- Conduit should enter the enclosure from the bottom.
- Sealed fittings should be installed at all cable entry points.
- Silicone sealant or equivalent should be applied around and inside all conduit entries.

Please refer to Figure 1 and Figure 2 as examples of recommended conduit installation details.

**NOTE:** See page 5 for the Model 227-003 Telephone.

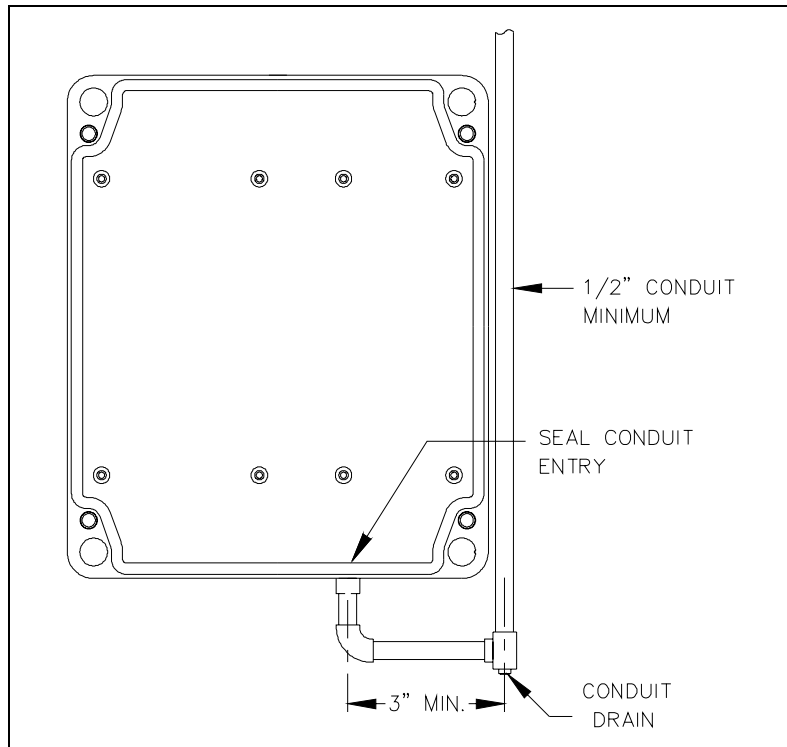

Figure 1. Bottom entry conduit installation details (RECOMMENDED for non-metallic enclosures)

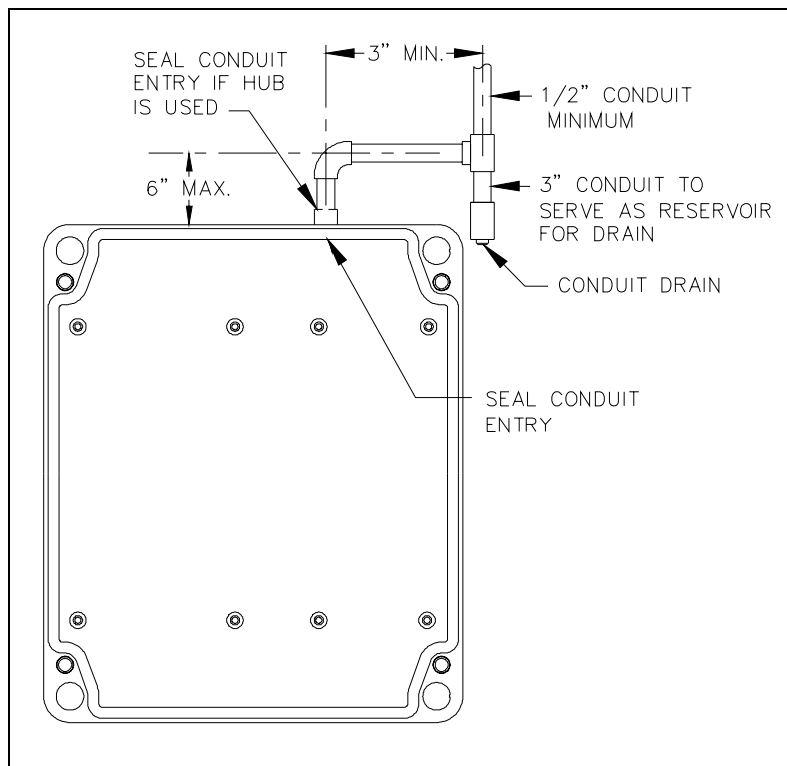

Figure 2. Top entry conduit installation details (NOT recommended)

## Model 227-003

The mounting and wiring instructions for the Model 227-003 S.M.A.R.T. Phone are as follows:

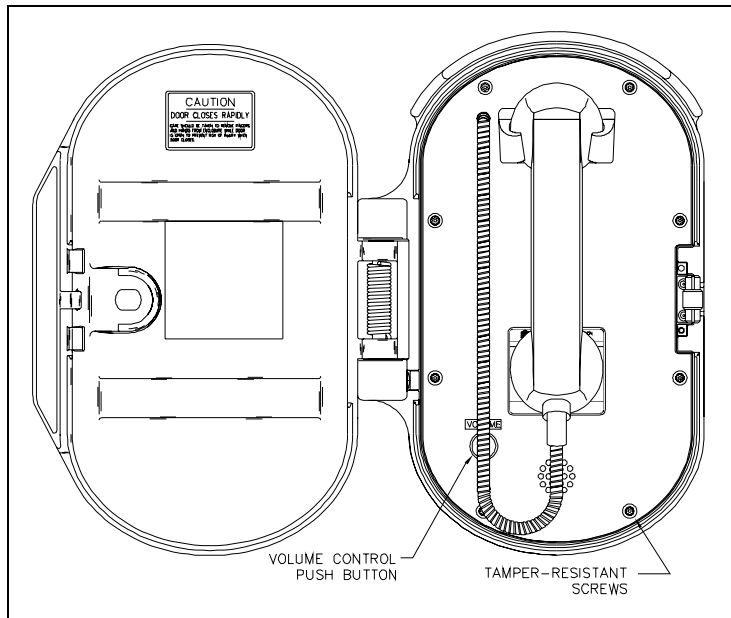

Figure 3. Model 227-003 S.M.A.R.T. Phone with spring loaded door in the open position

1. Remove the eight tamper-resistant screws from the front panel. Remove the front panel and set aside.
  - NOTE:** There is a 7-foot half-modular telephone cord attached to the PCBA on the rear.
2. There are eight mounting holes in the back of the enclosure in two 4-hole patterns. Determine which hole pattern will be used for mounting. See Figure 5.
  - For best results, use the  $7.875 \times 4.0$ -inch hole pattern for mounting to a wall (outside pattern).
  - Use the  $5.25 \times 4.0$ -inch hole pattern when using the Model 232-001 Pole Mounting Kit (inside pattern).

3. Insert four hole plugs (provided) in the unused holes.
4. Position the enclosure on the mounting surface and secure it with four fasteners.
  - The holes in the telephone enclosure accepts  $3/8$ -inch screws or bolts.
  - The Model 232-001 Pole Mounting Kit includes four  $3/8-16 \times 1$ -inch shoulder bolts with Teflon seal washers.



**NOTE** Use only the round head, hexagon head, or pan head screws that are provided.

**Do not** use screws designed to be countersunk for mounting the enclosure.

5. Install a conduit fitting in one of the  $1/2$ -inch NPT conduit entrances provided at both the top and bottom of the unit, and insert the conduit into the fitting. (The bottom location is preferred. See Figure 4.) Plug the unused access hole using the  $3/8$ -inch Allen drive plug provided.

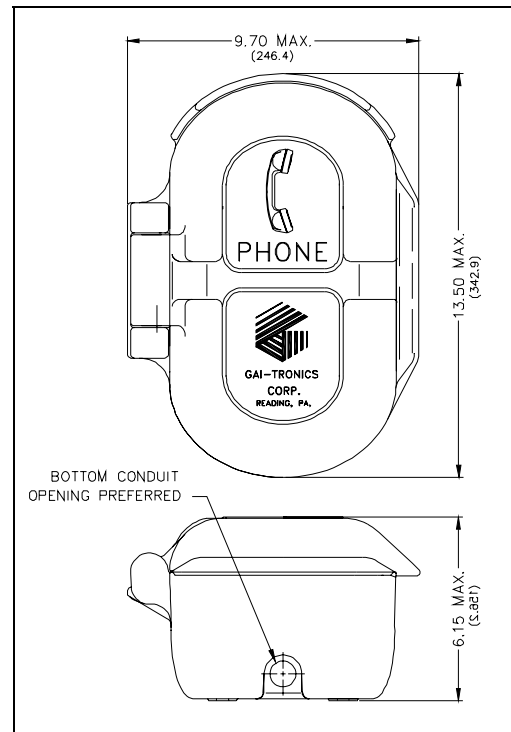

Figure 4. Model 227-003 Outline

6. Fish the free end of the half-modular telephone cord through the conduit.

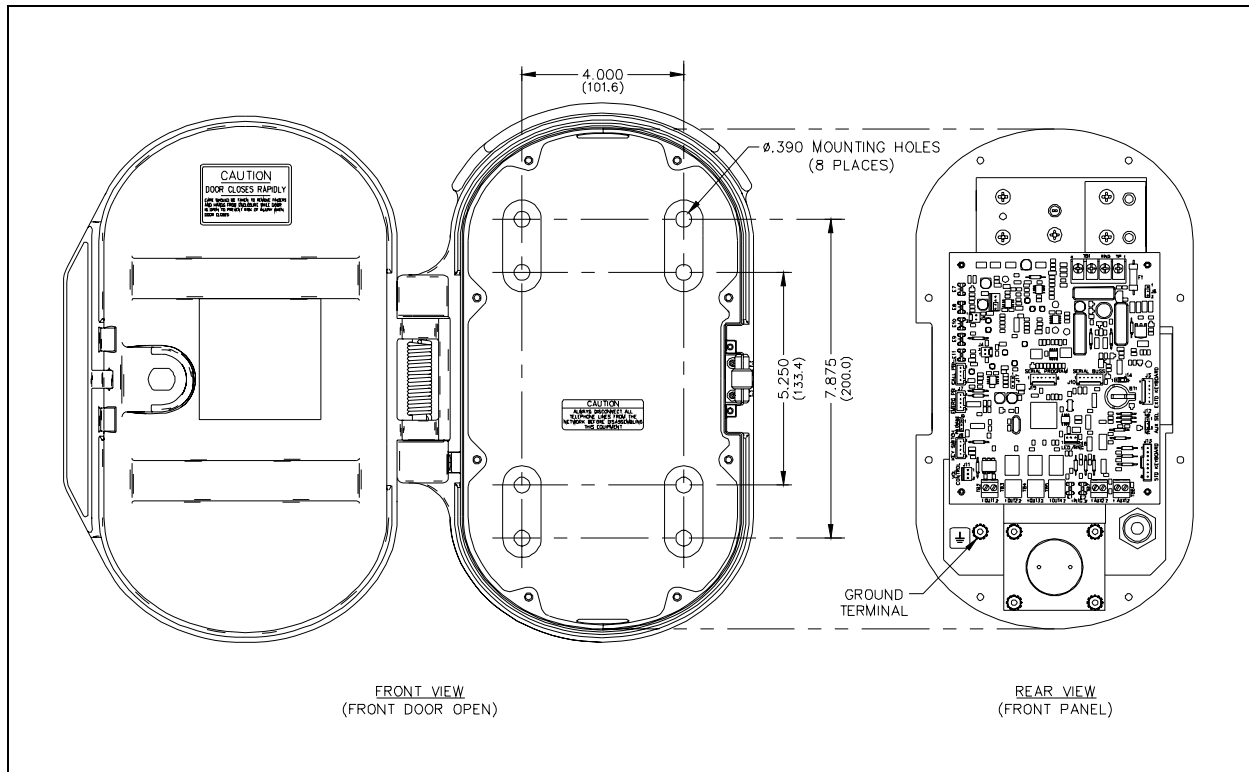

Figure 5. Model 227-003 Mounting Details

7. Replace the front panel assembly, and secure using the eight front panel tamper-resistant screws.
8. Connect the free end of the telephone cord to the incoming subscriber line using a USOC RJ11C jack (USA) or CA11A jack (Canada). Verify operation by calling to and from another phone.

## Model 257-003

1. Open the front door and remove the four outer screws from the mid-section. Carefully pull the enclosure apart until encountering a slight resistance on the left side.
2. Pull on the left side of the enclosure until the hinge plugs pull loose to separate the front and rear halves. Set the front half of the enclosure aside.
3. There are four mounting holes in the rear enclosure. Mount the enclosure on the wall using four ¼-20 machine screws with nuts and washers or #14 wood screws of appropriate length for the mounting surface.
4. Drill a 0.688-diameter hole at either drill spot on the bottom of the rear enclosure, and attach the gland bushing.
5. Reinsert the hinge pins to attach the front half of the enclosure. Fish the free end of the telephone cord through the gland bushing.
6. Close the mid-section and tighten the four screws.
7. Connect the free end of the modular telephone cord to the incoming subscriber line using a USOC RJ11C jack (USA) or a CA11A jack (Canada). Check the telephone by calling to and from another phone.

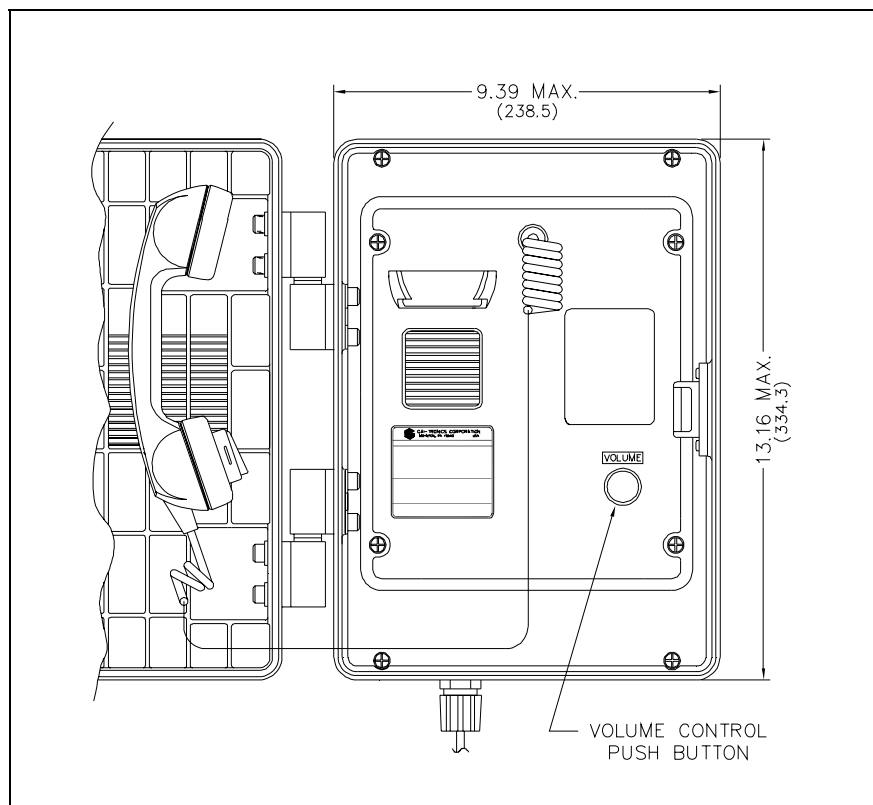

Figure 6. Model 257-003 S.M.A.R.T. Phone Outline  
(Front door open)



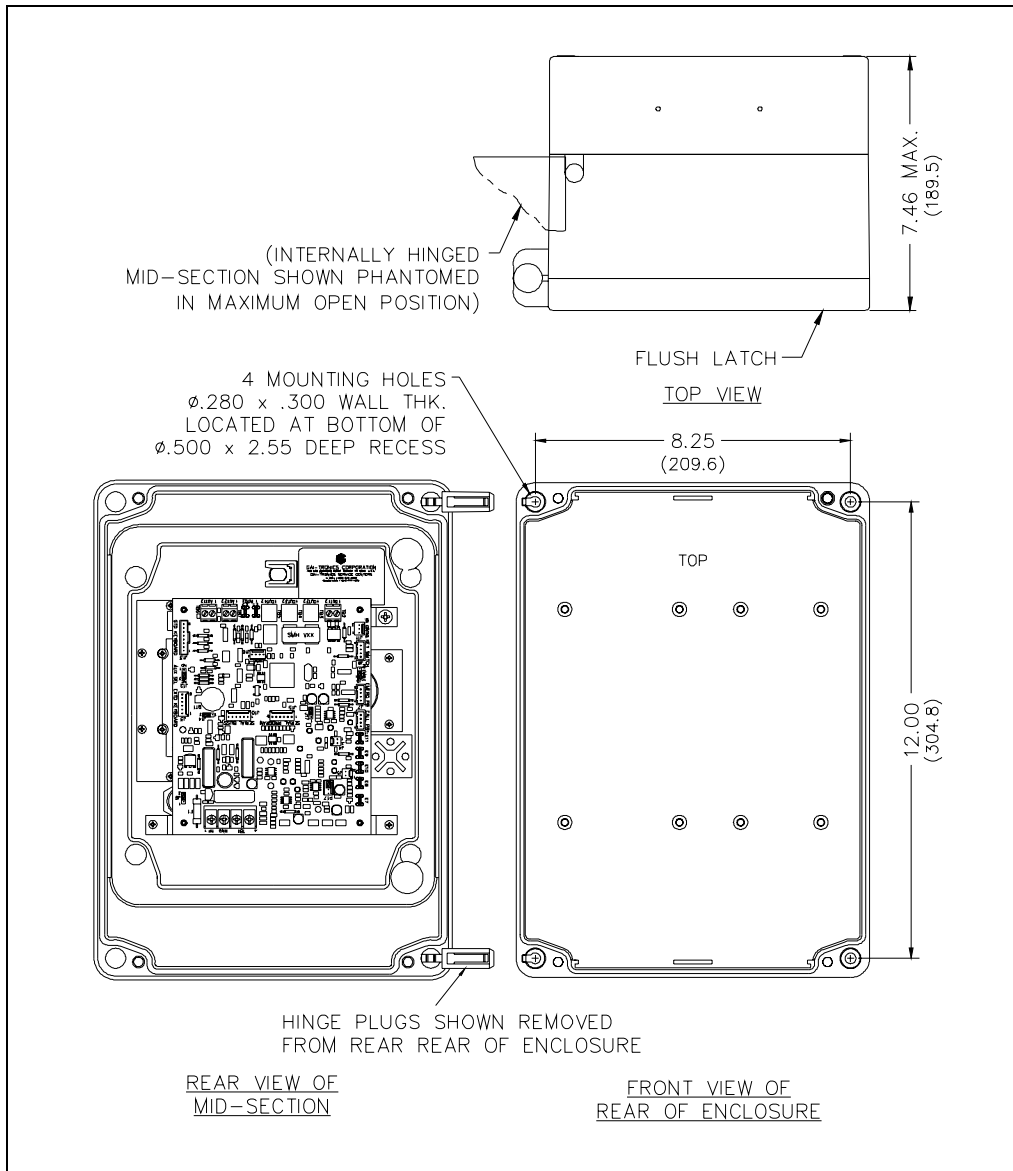

Figure 7. Model 257-003 Mounting Details

Model 277-003

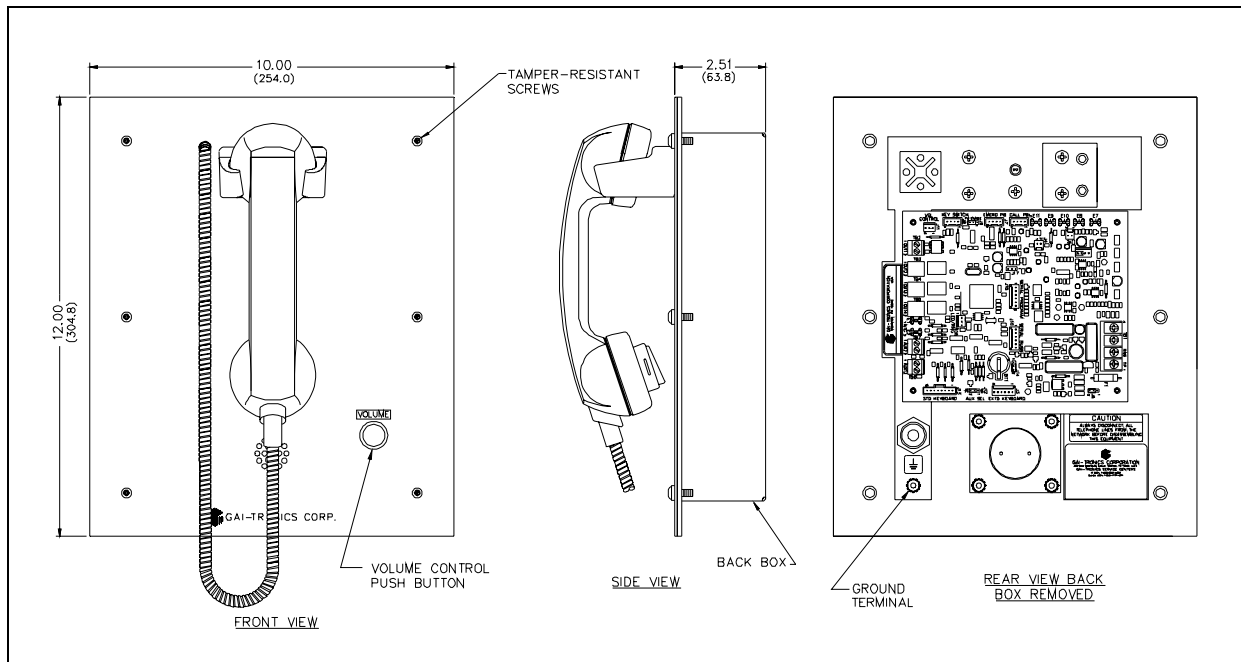

Figure 8. Model 277-003 Outline Drawing

Stanchion or Flush-mount Applications

1. When mounting in a GAI-Tronics Model 234 Series Stanchion or for flush-mount installations, the supplied back box must be used to mount the Model 277-003 Telephone. Mount the back box to the structure using the appropriate hardware. Refer to Figure 9 cutout dimensions.
2. If mounted outdoors, install the telephone line suppressor (customer-supplied) on the telephone line.
3. Remove the tapered plug from the top or bottom cable entry hole in the back box, and install the telephone line and cable fitting.
4. Use silicone sealant or equivalent around and inside all conduit entries.
5. Attach the telephone's front panel to the mounting flanges of the back box using the six supplied #10-32 tamper-resistant screws and washers.
6. Connect the USOC RJ11C (USA) or CA11A (Canada) modular connector of the supplied telephone cord to the incoming subscriber line, or (if applicable) the telephone line suppressor using the appropriate mating connector. Check the telephone by calling to and from another phone.

## Surface Mount Applications

**NOTE:** The back box is not required for use with the Model 236 Series Surface Mount Enclosure and should be removed.

1. Drill or punch conduit entries.



**WARNING**

**To prevent accidentally damaging equipment, drill all holes before mounting the telephone.**

2. Use silicone sealant or equivalent around the telephone gasket and the mounting surface for an effective perimeter seal. This is particularly important if the mounting surface is uneven.
3. Install the telephone line suppressor (customer-supplied) on the telephone line, if applicable.
4. Attach the telephone's front panel to the mounting flanges of the Model 236 Surface Mount Enclosure using the six #10-32 tamper-resistant screws and washers provided.
5. Connect the USOC RJ11C (USA) or CA11A (Canada) modular connector of the supplied telephone cord to the incoming subscriber line, or (if applicable) the telephone line suppressor using the appropriate mating connector. Check the telephone by calling to and from another phone.

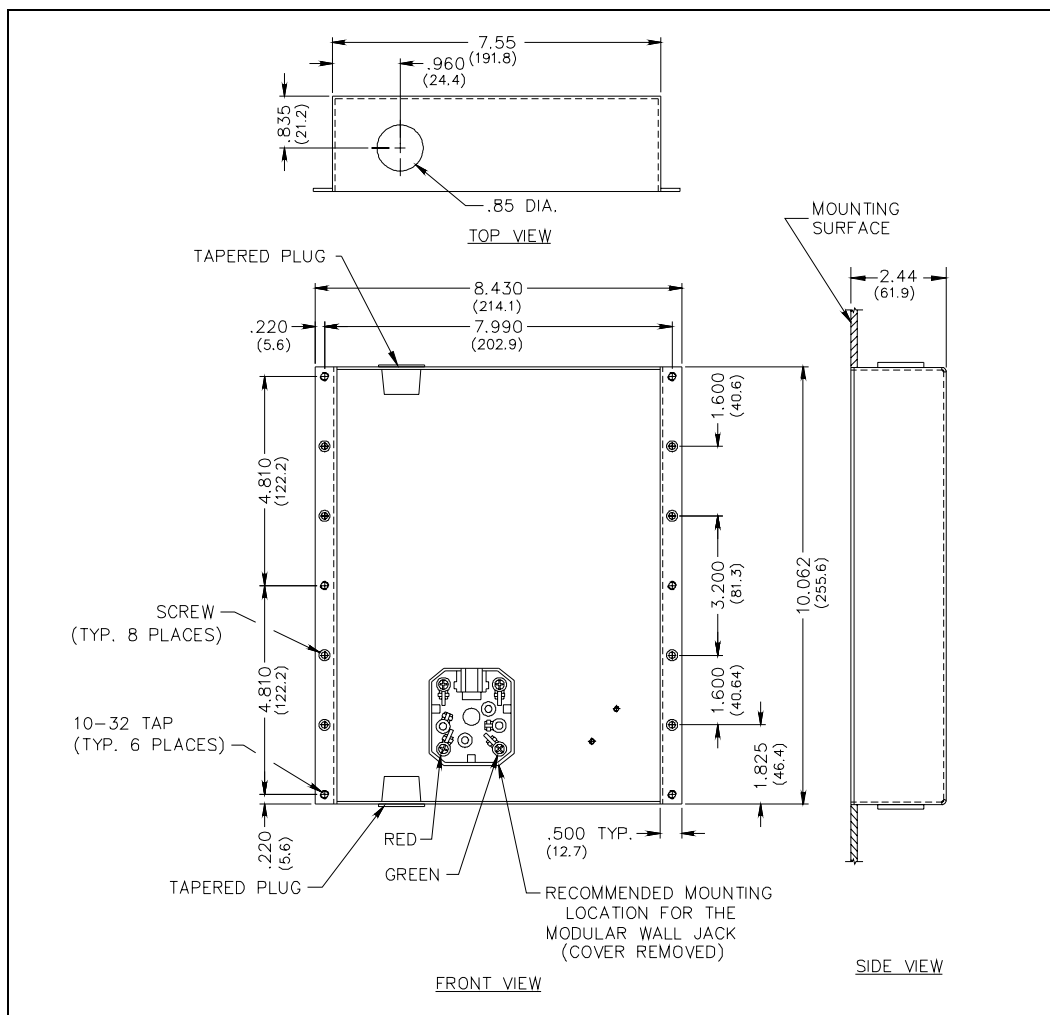

Figure 9. Model 277-003 Mounting Details

## External Power

The Model 40404-045 Plug-in Power Supply is available (sold separately) to provide an increase in the emergency phone's speaker output and a reduction in line current consumption. The 40404-045 requires 120 V ac input and provides a 5 V dc output to the unit's speaker amplifier circuits. The 40404-045 is provided with a connectorized, 4-foot power cable that plugs into P17 on the telephone PCBA.

**NOTE:** The 40404-045 is required only when setting the normal speaker volume to maximum does not produce the desired results or if available telephone line current falls below acceptable results.

## Setup

### Hardware Configuration

The hardware configuration options are explained in detail in the following sections and the necessary jumper settings are identified to enable or disable each option. We recommend reading the following sections, recording the desired parameters, and then making the necessary changes. We also recommend that you make a record of your settings. The following options are controlled by specific hardware configurations. See Figure 10 on page 12 for the jumper locations.

#### Auto-answer Configuration

*Factory Setting:* Auto-answer feature enabled

The Auto-answer feature enables or disables the automatic answering of an incoming call, which allows TMA to monitor the health of this phone via polling. When the Auto-answer feature is enabled, the phone automatically answers the call and attempts to communicate with TMA. If the caller is not TMA, then the phone rings its sounder to alert a user to lift the handset off-hook.

*Enable:* Insert the J14 jumper on pins 2 and 3.

*Disable:* Insert the J14 jumper on pins 1 and 2. (Do not use this setting except under the direction of GAI-Tronics personnel.)

**NOTE:** The Auto-answer feature must be enabled during remote programming, and to allow the GAI-Tronics Telephone Management Application PC to contact the phone.

#### Polarity Configuration

*Factory Setting:* Non-polarity sensitive

This telephone can be configured to be polarity or non-polarity sensitive. With the non-polarized setting, the telephone operates with the telephone line's positive terminal connected to either the tip or the ring. With the polarized setting, the telephone only operates with the telephone line's positive terminal connected to the tip.

*Non-polarity Sensitive:* Insert the J6 jumper on pins 2 and 3.

*Polarity Sensitive:* Insert the J6 jumper on pins 1 and 2.

## Auxiliary Output

Each telephone includes one isolated solid state switch capable of switching a maximum of 48 V dc, 125 mA or 28 Vrms ac, 80 mArms. TB2 (OUT1) on the phone PCBA provides the connections for the auxiliary output. Refer to Figure 10 for the location of the TB2.

The auxiliary output allows for control of external electric devices such as a ringing indicator lamp. This isolated contact output activates while the telephone sounds its ringer at the start of an incoming call and will extinguish when the handset is lifted from its cradle (call answered).

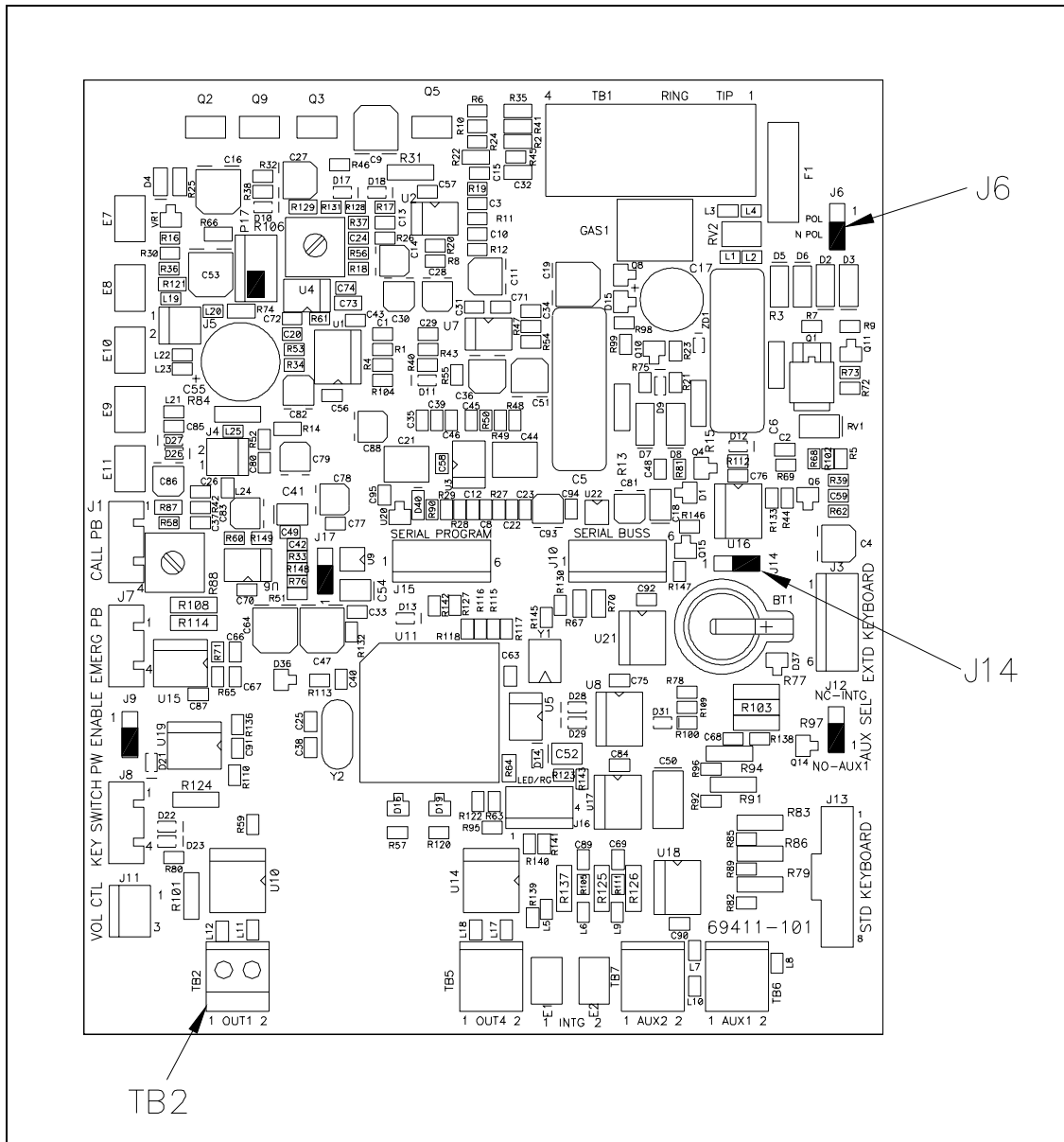

Figure 10. S.M.A.R.T. Phone PCBA

## Programming

All S.M.A.R.T. Phone models are programmable. The phone settings are initially programmed during manufacturing and testing. These default settings from the factory can be found in **Table R-2**. After the S.M.A.R.T. Phone is installed, you have the option of changing the default settings. This manual provides instructions for programming basic features needed to initially set up the phone from another touch-tone phone.

More advanced programming requires a PC and the TMA software. For programming using the TMA terminal, refer to the manual provided with the software, or contact the GAI-Tronics Field Service Department.

**NOTE**

Use a handset phone exclusively when programming the S.M.A.R.T. phone remotely. If a speakerphone is used for programming background noise could lead to the incorrect settings. (Cellular telephone is not recommended.)

### Enter the Programming Mode

Read the entire programming section and carefully plan your programming before beginning the process. Write down the key sequence from the *Command* column of **Table R-1, Basic Programming Commands**, for the features that you need. Having your programming information written down allows you to enter the key sequence at a steady pace.

Complete the following steps to enter the programming sequence from a remote DTMF telephone:

1. Call the S.M.A.R.T. telephone to be programmed. (Do not use a cellular phone.)
2. Listen for a confirmation tone during ringing, which signals that the telephone has answered.
3. Press \*\*\* to enter the programming mode.
4. Wait two seconds.
5. Enter \*\*0000 (0000 is the factory default maintenance PIN #.)  
**NOTE:** After sending the maintenance PIN # to the phone, entering \*20 will allow for confirmation of maintenance access to the phone. If access is granted, the phone responds with six DTMF digits. If access is denied, the phone responds with two DTMF digits. If access is denied, repeat step 5 to again request access.
6. Complete the desired programming. Refer to the Basic Programming Commands section for options.
7. Listen for a confirmation tone at the end of each programming sequence, which indicates the programming change was accepted.

**NOTE**

Delays during programming greater than 5 seconds causes a programming time-out. If this occurs, you will hear a beep before the programming sequence is completed and you must reenter the sequence.

8. When finished programming, press \*99 to exit the programming mode.

### Basic Programming Commands

The following programming command can be entered from any touch-tone telephone. Acceptance of a data transfer command is indicated via a return code transmitted as an audible DTMF tone.

#### Auto-dial Memory

When the handset is lifted, the Auto-dial S.M.A.R.T. Phone dials a pre-programmed telephone number (the primary number). If the call cannot connect (line busy, no answer), the phone will redial using the first backup (roll over) number. If again the call cannot connect, the phone will redial using the second backup (roll over) number. This sequence will continue until either the call is answered, or the programmed number of retries is reached.

Use the **\*1** command to program these three auto-dial numbers. The three auto-dial telephone numbers are labeled as 11 (primary), 12 (first roll over), and 13 (second roll over). You may program these for three different numbers, or set them to the same telephone number. Each auto-dial memory storage location accommodates up to 24 characters.

To enter the auto-dial number into memory storage, or to change the number in storage, enter

**\*11<N><CHAR>#**

<b>*1</b>	Data transfer command
<b>1&lt;N&gt;</b>	Auto-dial memory location (N = 1, 2, or 3)
<b>&lt;CHAR&gt;</b>	Telephone number to be stored in memory location (up to 24). Valid entries are 0-9 and the following 2-digit codes: *1 provides a 0.6 second pause in the dialing sequence, *2 provides a DTMF #, and ** provides a DTMF *.
<b>#</b>	End-of-string indicator

The command **\*115551212#**, for example, sets the primary number to 555-1212.

After each auto-dial memory storage location is successfully programmed, the phone returns a system-generated DTMF check-digit.

If the phone is installed on a ring down telephone line, clear the first auto-dial memory using the command **\*111#**.

**Call Time-out**

The call time-out feature, which is used to limit the duration of calls, can be set between one minute and 4.5 hours. The time limit is set by entering a number from 120 to 32400.

This number represents the number of half-second increments of duration. Entering 0 results in a call time-out of 4.5 hours.

Enter **\*37<120~32400>#** to assign a time limit, or change an existing time limit.

<b>*37</b>	Data transfer command
<b>&lt;120~32400&gt;</b>	Call duration (60–16,200 seconds, 0 = 4.5 hours) – See example below.
<b>#</b>	End of string indicator

Multiply the desired time limit, in minutes, by 120 to determine the call duration.

Example: For a call duration of 5 minutes:

5 minutes × 120 = **600**

Therefore, you would enter the character string **\*37600#**, and the phone returns a system-generated DTMF check-digit.

Table R-1. Basic Programming Commands

Command:	Return:	Description:
*1nn <charac>#	c	Write Memory nn (11-13) with characters (up to 24)
*37<120~32400>#	c	Write Call Time-out (120-32400 × ½ sec, 0 disables)

'c' in the above return fields is the system-generated DTMF check-digit.

Table R-2 - Default Configuration

Parameter	Default Setting
Auto-answer	Enabled (J14)
Rings Before Auto-answer	0 (not configurable)
Rings After Auto-answer	10 (not configurable)
Dial Tone Detection	Enabled (N/A unless keypad is disabled)
Dial Tone Waiting Period	10 seconds
Mute Before Dial	Enabled
Audio Receive Level	Midrange
Call Time Out Period	7 min
DTMF Dial Rate	100:100 ms



# Maintenance

## Service

If your S.M.A.R.T. Phone requires service, contact your GAI-Tronics Regional Service Center for a return authorization number (RA#). Equipment should be shipped prepaid to GAI-Tronics with a return authorization number and a purchase order number. If the equipment is under warranty, repairs will be made without charge. Please include a written explanation of all defects to assist our technicians in their troubleshooting efforts.

Call 800-492-1212 inside the USA or 610-777-1374 outside the USA for help identifying the Regional Service Center closest to you.

## Preventive Maintenance for Model 277-003

Stainless steel does not require maintenance to prevent corrosion from occurring. Different installation locations may require more regular maintenance than others, depending on the environment and exposure to airborne contaminants. The following maintenance steps should be performed on a regular basis or when corrosion is first noticed on your Model 277-003.

### Cleaning

- For general cleaning, wipe the surface with a cleanser or a cleanser and water mixture. Any cleanser that is safe for glass is usually safe for stainless steel. Wipe dry.
- If corrosion or rusting is noticed, remove with a non-abrasive commercial cleanser and water. Rub stained areas in the same direction as the existing grain. Stubborn stains may be removed with a magnesium oxide, ammonia, and water paste. Wipe clean with water rinse and dry.

### Prevention

Automotive wax provides the best results in preventing corrosion on stainless steel. Simply apply wax, let dry to a haze, and buff to a shine with a clean dry cloth. This application should protect the telephone surface for many months as it will allow natural reformation of the chromium oxide layer.

**Do NOT use steel wool, sandpaper, mineral acids, bleaches, or chlorine cleansers on the stainless surface.**

# Specifications

TMA Compatibility profile type ..... GTC S.M.A.R.T. Handset

## Electrical

Minimum loop current (48 V dc only) ..... 20 mA

Operation ..... Loop start

Volume control ..... 4 step (-6 dB, 0 dB, 6 dB, 12 dB)

Auxiliary output (isolated solid state switch)..... 48 V dc @ 125 mA  
28 V<sub>RMS</sub> @ 80 mA<sub>RMS</sub>

## Mechanical

Operating temperature range.....-40° C to +60° C

Relative humidity ..... to 95%, no condensation

### Model 227-003

#### Construction

Enclosure ..... Thick-walled cast aluminum with protective gray coating

Panel..... 0.125-inch brushed aluminum

Handset/cord ..... G-style with 19-inch armored cord and internal lanyard

Dimensions ..... 13.50 H × 9.70 W × 6.15 D inches

Mounting ..... Eight 0.39-inch diameter holes

Weight ..... 14.5 lbs.

### Model 257-003

Construction..... High impact, glass-reinforced polyester

Handset/cord ..... 6-foot Hytrel® cord with noise-canceling microphone

Dimensions ..... 13.20 H × 9.40 W × 7.40 D inches

Mounting ..... Four 0.28-inch diameter holes

Weight ..... 10.0 lbs.

### Model 277-003

#### Construction

Front Panel..... 14-gauge (0.075 inch) type 304 brushed stainless steel

Back Box ..... 16-gauge (0.060) cold-rolled steel with black polyurethane finish

Handset/cord ..... G-style with 29-inch armored cord and internal lanyard

#### Dimensions

Front Panel..... 12.00 H × 10.00 W inches

Back Box ..... 10.06 H × 8.43 W × 2.44 D inches

Back Box (depth from mounting surface) ..... 2.38 inches

Panel Cutout ..... 10.06 H × 8.43 W inches

Weight ..... 7.0 lbs.

Approvals

Safety of Information Technology Equipment..... UL/CSA 60950

Enclosures for Electrical Equipment ..... UL 50, Type 3R  
Model 246-003 only: UL 50

47 CFR Part 68

Certification Number ..... US: ADGTE04B0414HAC

Ringer Equivalence Number ..... .4B

Network connection (USOC)..... RJ11

IC Information (Canada)

IC Certification Number ..... 882B-GTC S.M.A.R.T.

Ringer Equivalence Number ..... .4B

Connection Method ..... CA11A

## User Instructions (USA)

This equipment complies with Part 68 of the FCC rules and the requirements adopted by the ACTA. On this equipment is a label that contains, among other information, a product identifier in the format US:AAAEQ##TXXXX. If requested, this number must be provided to the telephone company.

A plug and jack used to connect this equipment to the premises wiring and telephone network must comply with the applicable FCC Part 68 rules and requirements adopted by the ACTA. A compliant telephone cord and modular plug is provided with this product. It is designed to be connected to a compatible modular jack that is also compliant. See installation instructions for details.

The REN is used to determine the number of devices that may be connected to a telephone line. Excessive RENs on the telephone line may result in the devices not ringing in response to an incoming call. In most but not all areas, the sum of the RENs should not exceed five (5.0). To be certain of the number of devices that may be connected to a line, as determined by the total RENs, contact the local telephone company. For products approved after July 23, 2001, the REN for this product is part of the product identifier that has the format US:AAAEQ##TXXXX. The digits represented by ## are the REN without a decimal point (e.g., 03 is an REN of 0.3). For earlier products, the REN is separately shown on the label.

If this equipment [GAI-Tronics telephone] causes harm to the telephone network, the telephone company will notify you in advance that temporary discontinuance of service may be required. But if advance notice isn't practical, the telephone company will notify the customer as soon as possible. Also, you will be advised of your right to file a complaint with the FCC if you believe it is necessary.

The telephone company may make changes in its facilities, equipment, operations, or procedures that could affect the operation of the equipment. If this happens the telephone company will provide advance notice in order for you to make necessary modifications to maintain uninterrupted service.

If trouble is experienced with this equipment [GAI-Tronics telephone], for repair or warranty information, please contact GAI-Tronics Corporation at 800-492-1212 or [www.gai-tronics.com](http://www.gai-tronics.com). If the equipment is causing harm to the telephone network, the telephone company may request that you disconnect the equipment until the problem is resolved.

Connection to party line service is subject to state tariffs. Contact the state public utility commission, public service commission or corporation commission for information.

This equipment uses a telephone handset and it is hearing aid compatible.

## User Instructions (Canada) CP-01, Issue 8, Part I: Section 14.1

**NOTICE:** The Industry Canada label identifies certified equipment. This certification means that the equipment meets certain telecommunications network protective, operational and safety requirements as prescribed in the appropriate Terminal Equipment Technical Requirements document (s). The Department does not guarantee the equipment will operate to the user's satisfaction. Before installing this equipment, users should ensure that it is permissible to be connected to the facilities of the local telecommunications company. The equipment must also be installed using an acceptable method of connection. The customer should be aware that compliance with the above conditions may not prevent degradation of service in some situations. Repairs to certified equipment should be coordinated by a representative designated by the supplier. Any repairs or alterations made by the user to this equipment, or equipment malfunctions, may give the telecommunications company cause to request the user to disconnect the equipment. Users should ensure for their own protection that the electrical ground connections of the power utility, telephone lines and internal metallic water pipe system, if present, are connected together. This precaution may be particularly important in rural areas.



**CAUTION**

**Users should not attempt to make such connections themselves, but should contact the appropriate electric inspection authority, or electrician, as appropriate.**

## CP-01, Issue 8, Part I: Section 14.2

**NOTICE:** The **Ringer Equivalence Number** (REN) assigned to each terminal device provides an indication of the maximum number of terminals allowed to be connected to a telephone interface. The termination on an interface may consist of any combination of devices subject only to the requirement that the sum of the Ringer Equivalence Numbers of all the devices does not exceed 5.

Replacement Parts

Part No.	Description	227-003	257-003	277-003
233-001	Model 233-001 Tamper-Resistant Screwdriver	■		■
12562-104	PCBA Replacement Kit (S.M.A.R.T. Handset)	■	■	■
13707-008	Ringer	■	■	■
28299-007	Tamperproof Screws			■
28229-002	Tamperproof Screw (Torx-T25)	■		
28118-001	Phillips Head Screw		■	
10113-020	Handset Assembly with Lanyard Armored Cord, 15-inch	■		
10113-021	Handset Assembly with Lanyard Armored Cord, 29-inch			■
10113-022	Hytrel® Cord Handset Assembly, 6-foot		■	
12512-001	Hookswitch/Cradle Kit		■	
12512-002	Hookswitch/Cradle Kit (metallic)	■		■
12576-119	Front Panel Replacement Kit	■		
40404-045	Optional Power Supply	■	■	■

## Confidentiality Notice

This manual is provided solely as an installation, operation, and maintenance guide and contains sensitive business and technical information that is confidential and proprietary to GAI-Tronics. GAI-Tronics retains all intellectual property and other rights in or to the information contained herein, and such information may only be used in connection with the operation of your GAI-Tronics product or system. This manual may not be disclosed in any form, in whole or in part, directly or indirectly, to any third party.

# Warranty

---

Equipment. GAI-Tronics warrants for a period of one (1) year from the date of shipment, that any GAI-Tronics equipment supplied hereunder shall be free of defects in material and workmanship, shall comply with the then-current product specifications and product literature, and if applicable, shall be fit for the purpose specified in the agreed-upon quotation or proposal document. If (a) Seller's goods prove to be defective in workmanship and/or material under normal and proper usage, or unfit for the purpose specified and agreed upon, and (b) Buyer's claim is made within the warranty period set forth above, Buyer may return such goods to GAI-Tronics' nearest depot repair facility, freight prepaid, at which time they will be repaired or replaced, at Seller's option, without charge to Buyer. Repair or replacement shall be Buyer's sole and exclusive remedy. The warranty period on any repaired or replacement equipment shall be the greater of the ninety (90) day repair warranty or one (1) year from the date the original equipment was shipped. In no event shall GAI-Tronics warranty obligations with respect to equipment exceed 100% of the total cost of the equipment supplied hereunder. Buyer may also be entitled to the manufacturer's warranty on any third-party goods supplied by GAI-Tronics hereunder. The applicability of any such third-party warranty will be determined by GAI-Tronics.

Services. Any services GAI-Tronics provides hereunder, whether directly or through subcontractors, shall be performed in accordance with the standard of care with which such services are normally provided in the industry. If the services fail to meet the applicable industry standard, GAI-Tronics will re-perform such services at no cost to buyer to correct said deficiency to Company's satisfaction provided any and all issues are identified prior to the demobilization of the Contractor's personnel from the work site. Re-performance of services shall be Buyer's sole and exclusive remedy, and in no event shall GAI-Tronics warranty obligations with respect to services exceed 100% of the total cost of the services provided hereunder.

Warranty Periods. Every claim by Buyer alleging a defect in the goods and/or services provided hereunder shall be deemed waived unless such claim is made in writing within the applicable warranty periods as set forth above. Provided, however, that if the defect complained of is latent and not discoverable within the above warranty periods, every claim arising on account of such latent defect shall be deemed waived unless it is made in writing within a reasonable time after such latent defect is or should have been discovered by Buyer.

Limitations / Exclusions. The warranties herein shall not apply to, and GAI-Tronics shall not be responsible for, any damage to the goods or failure of the services supplied hereunder, to the extent caused by Buyer's neglect, failure to follow operational and maintenance procedures provided with the equipment, or the use of technicians not specifically authorized by GAI-Tronics to maintain or service the equipment. **THE WARRANTIES AND REMEDIES CONTAINED HEREIN ARE IN LIEU OF AND EXCLUDE ALL OTHER WARRANTIES AND REMEDIES, WHETHER EXPRESS OR IMPLIED BY OPERATION OF LAW OR OTHERWISE, INCLUDING ANY WARRANTIES OF MERCHANTABILITY OR FITNESS FOR A PARTICULAR PURPOSE.**

## Return Policy

---

If the equipment requires service, contact your Regional Service Center for a return authorization number (RA#). Equipment should be shipped prepaid to GAI-Tronics with a return authorization number and a purchase order number. If the equipment is under warranty, repairs or a replacement will be made in accordance with the warranty policy set forth above. Please include a written explanation of all defects to assist our technicians in their troubleshooting efforts.

Call 800-492-1212 (inside the USA) or 610-777-1374 (outside the USA) for help identifying the Regional Service Center closest to you.